

# EMG-30ASA Series Servo Motor



## FEATURES

- 220 VAC
- **Rated Torque of 2025 oz-in**
- **3000 Watt Power Rating**
- **Rated Speed 2000 RPM**
- **Maximum Speed 3000 RPM**
- **Peak Torque up to 300% of Rated Torque**
- **Peak Current up to 300% of Rated Current**
- **131,072 PPR Absolute Encoder Attached**
- **Enclosed and Self-Cooled**
- **Brake Option Available**
- **CE Certified**



## DESCRIPTION

Anaheim Automation's Digital AC Servo Motors offer a simple solution to servo applications involving speed and positioning control. The EMG-30ASA Servo Motor comes standard with a 131,072 Pulses Per Revolution (PPR) Absolute Encoder, runs at a maximum speed of 3,000 RPM, provides peak values up to 300% of the rated torque and current values, and has a rated torque of 2025 oz-in with a 3000 Watt power rating. These enclosed and self-cooled motors also provide longer motor life and higher reliability. The EMG-30ASA Servo Motors enable industrial motion control applications to attain a great combination of speed and positioning functionality.

## SPECS

Model #	Rated Torque (oz-in)	Rated Power (Watts)	Rated Speed (RPM)	Max Speed (RPM)	Rated Current (A rms)	Brake (24VDC)	Inertia (oz-in-sec <sup>2</sup> )	Torque Constant $K_T$ (oz-in/A)	Resistance (ohms)	Inductance (mH)	Length (mm)	Weight (lbs)
EMG-30ASA22	2025	3000	2000	3000	18	No	0.58485	128.6	0.29	2.79	228	36.66
EMG-30ASA24	2025	3000	2000	3000	18	Yes	0.63017	128.6	0.29	2.79	299	44.5

## TORQUE CURVE

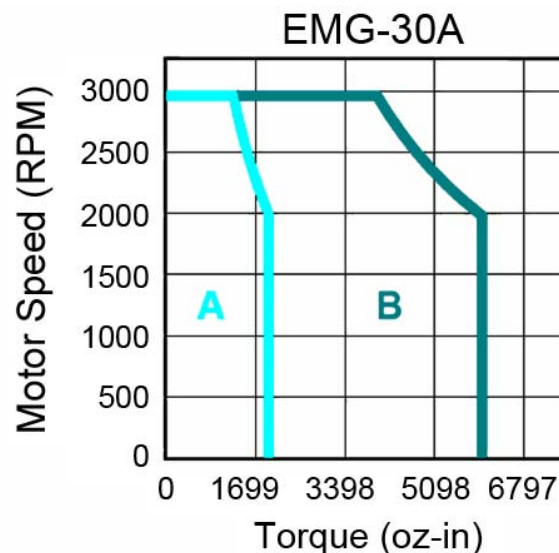

A: Continuous Working Area  
B: Repeatedly Working Area

L011598

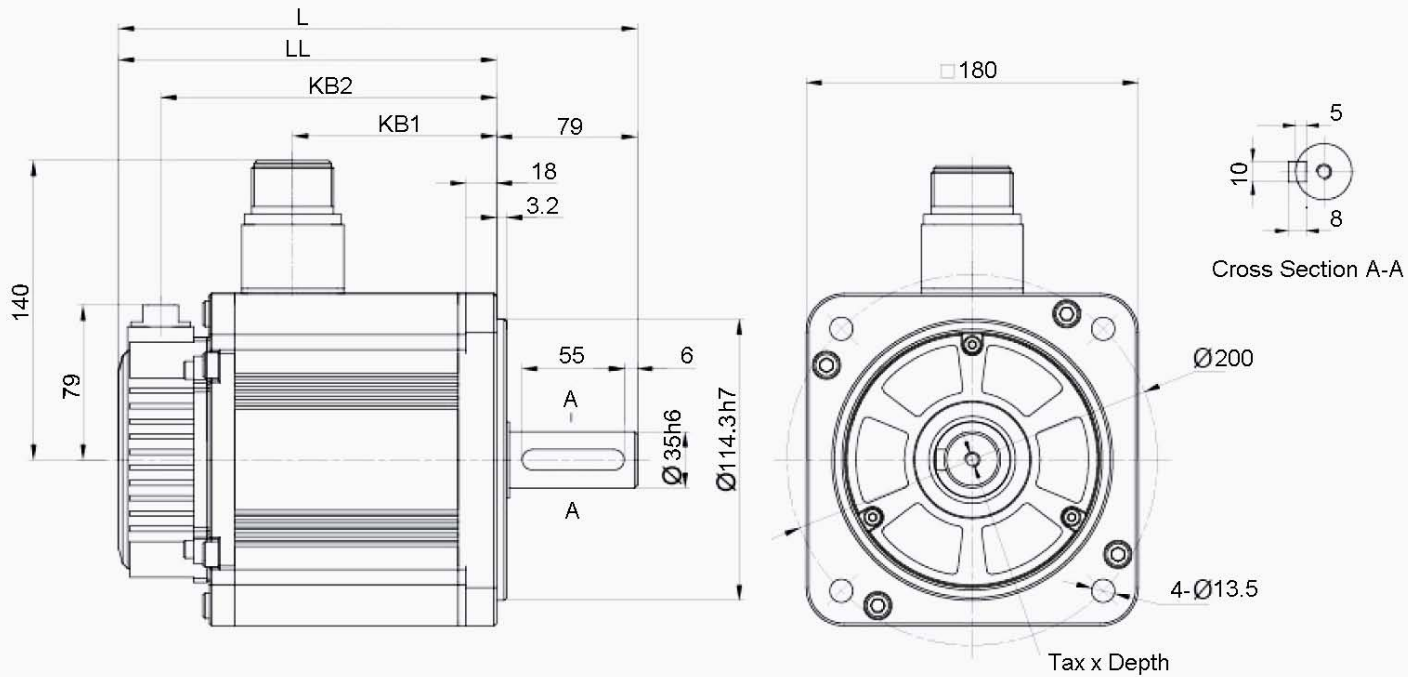

Note: All Dimensions in millimeters

Model #	L	LL	KB1	KB2
EMG-30ASA22	307	228	143	203
EMG-30ASA24	378	299	143	274

Note: the EMG-30ASA24 are Servo Motors with holding brakes.

**Encoder Connector Specification:**



Pin No.	Signal
K	S+
L	S-
T	BAT+
S	BAT-
H	PG5V
G	PG0V
J	FG

**Motor Connector Specification:**

Pin No.	Signal
A	U
B	V
C	W
D	FG

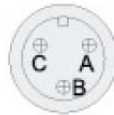
**Brake Connector Specification:**

Pin No.	Signal
A	B1
B	B2
C	-

<b>Receptacle:</b>	MS3102A10SL-3P
<b>Plug:</b>	MS3106A10SL-3S
<b>Cable Clamp:</b>	MS3057-4A

Power Requirement: 220VAC	Vibration: 49 m/s <sup>2</sup>	Running Air Pressure: 86 to 106 kPa
Insulation Class: F	Ambient Temperature: 20% to 80% RH	Insulation Voltage Endurance: AC 1800C, 50Hz, 1 min
Ambient Temperature: 0°C to 40°C	Running Humidity: Not More Than 90%, Under 25°C	Insulation Impedance: Not Less Than 50M Under Normal Conditions
Running Temperature: -25°C to 40°C		

**Compatible Driver:**

Part Number	Description
PRONET-30AEA-EC	Servo Driver

**Compatible Cables:**

Part Number	Description
PDM-GD12-05	Power Cable
PAP-GA24-05	Encoder Cable

